

PUBLISHED VERSION

Rollins, J.; Ottaway, David John; Zucker, Mike; Weiss, R.; Abbott, R.
Solid-state laser intensity stabilization at the 10(-8) level, *Optics Letters*, 2004; 29 (16):1876-1878.

Copyright © 2004 Optical Society of America

PERMISSIONS

http://www.opticsinfobase.org/submit/review/copyright_permissions.cfm#posting

This paper was published in *Optics Letters* and is made available as an electronic reprint with the permission of OSA. The paper can be found at the following URL on the OSA website <http://www.opticsinfobase.org/abstract.cfm?URI=ol-29-16-1876>. Systematic or multiple reproduction or distribution to multiple locations via electronic or other means is prohibited and is subject to penalties under law.

OSA grants to the Author(s) (or their employers, in the case of works made for hire) the following rights:

(b)The right to post and update his or her Work on any internet site (other than the Author(s') personal web home page) provided that the following conditions are met: (i) access to the server does not depend on payment for access, subscription or membership fees; and (ii) any such posting made or updated after acceptance of the Work for publication includes and prominently displays the correct bibliographic data and an OSA copyright notice (e.g. "© 2009 The Optical Society").

17th December 2010

<http://hdl.handle.net/2440/48379>

Solid-state laser intensity stabilization at the 10^{-8} level

Jameson Rollins, David Ottaway, Michael Zucker, and Rainer Weiss

LIGO Laboratory, Massachusetts Institute of Technology, MIT NW17-161, 175 Albany Street, Cambridge, Massachusetts 02139

Richard Abbott

LIGO Laboratory, California Institute of Technology, Mail Stop #18-34, Pasadena, California 91125

Received February 5, 2004

A high-power, low-noise photodetector, in conjunction with a current shunt actuator, is used in an ac-coupled servo to stabilize the intensity of a 10-W cw Nd:YAG laser. A relative intensity noise of $1 \times 10^{-8} \text{ Hz}^{-1/2}$ at 10 Hz is achieved. © 2004 Optical Society of America

OCIS codes: 140.3850, 040.5150.

Laser interferometry is a powerful measurement tool that has allowed phenomenal improvements in metrology for industrial and scientific applications. Laser intensity fluctuations can limit the sensitivity of interferometry,^{1,2} as well as other high-precision optical measurements.^{3,4}

Laser intensity fluctuations limit the sensitivity of interferometers through several mechanisms. One obvious coupling is masking the signal at the detector; often this effect is minimized by holding the output of the interferometer to a minimum intensity and using a modulation–demodulation technique to shift the measurement frequency up to where the intensity fluctuations are smaller. Another coupling is through radiation pressure on the sensing mirrors, which in the case of gravitational-wave detectors are suspended test masses in the range from 1 to 40 kg. The impact of the photons causes displacement noise at the interferometer output.

Intensity fluctuations come in two basic forms. The first, caused by the Poisson distribution of photons in the light beam, is known as shot noise and leads to a standard deviation equal to the square root of the intensity. The second is known as technical intensity noise and is caused by fluctuations in excess of the Poisson fluctuations, which are typically linearly proportional to the light power. We deal with the latter fluctuations here and address the challenge of approaching the Poisson-limited intensity fluctuations in a measurement band from 10 to 100 Hz.

The required intensity noise performance for the Advanced Laser Interferometer Gravitational Wave Observatory (LIGO) can be seen in Fig. 1. The most demanding part of this requirement is a relative intensity noise of $2 \times 10^{-9} \text{ Hz}^{-1/2}$ at 10 Hz. In this Letter we report on the progress toward meeting this tight requirement in a single-frequency solid-state master oscillator power amplifier (MOPA) laser⁵ by feedback control of the current to the amplifier pump diodes.

Current plans for the Advanced LIGO call for the use of a 180-W injection-locked laser system.⁶ This higher-power system may be accompanied by higher relative intensity noise levels, which may require more servo gain to reach the same relative intensity noise level. Other than issues of servo gain, the main

hurdles to achieving excellent intensity noise performance are sensor noise, nonlinearities in the servo electronics, and beam geometry fluctuations. These other limitations are common to both injection-locked and MOPA configurations; therefore the following system will be applicable to the Advanced LIGO.

The laser that was used to test and develop this intensity stabilization servo is a prestabilized laser (PSL) system that is similar to the PSL system used in the initial LIGO.² It consists of a 10-W MOPA that can be locked to a high-finesse reference cavity for frequency stabilization.⁷

More important, in the context of this work the PSL also has a monolithic triangular Fabry–Perot cavity known as the premode cleaner (PMC).⁸ This cavity acts as a high-precision spatial mode filter that reduces laser beam geometry fluctuations by a factor

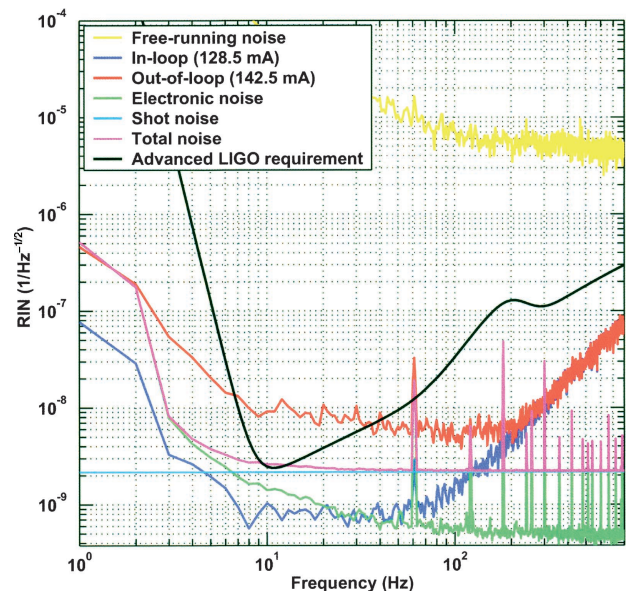

Fig. 1. Relative intensity noise (RIN) as measured by in-loop and out-of-loop photodetectors. The expected shot noise and measured electronic noise levels are shown in the light blue and green traces, respectively. The black curve shows the Advanced LIGO requirement. (Data taken June 29, 2003.)

of 130. This is important because the responsivity of the photodiodes varies across their surfaces. Hence, variations in the position of the beam on the photodiode lead to variations in the photocurrent, resulting in increased noise. The frequency cutoff of the filter cavity is 1.75 MHz, which, being well outside the bandwidth of the servo control system (30 kHz), has no effect on the design of the intensity control servo.

The MOPA has two main diode current adjustment actuators useful for intensity stabilization: a high-range, but relatively slow, low-frequency current adjust (LFCA) and a lower-range, but faster, current shunt (CS). Both actuators modulate the current to the main power amplifier diodes of the laser.

The LFCA sums directly to the power amplifier pump-diode current supply at the MOPA control box. It has a range of approximately 10% of the total drive current, with a response of up to 20 kHz, at which point it falls off steeply at a rate of roughly 80 dB/decade.

The CS is a circuit in parallel with the power amplifier pump diodes that is able to modulate the current to the diode at approximately 1% of the total current.⁹ The response is flat up to 3 kHz, where there is only a single pole, making this actuator useful to much-higher frequencies.

The design of the intensity stabilization servo was guided primarily by the decision to make the photodetector, and therefore the entire control loop, ac coupled. Although this makes the design of the servo slightly more complicated, it bypasses the need for a highly stable external dc reference. The basic block diagram for the servo can be seen in Fig. 2. The photodetector is placed after the PMC to take advantage of its beam-stabilizing properties.

The CS alone does not have enough range below 1 Hz to control the free-running laser intensity noise. To circumvent this problem, the control signal to the CS is picked off, put through a low-pass filter, and then fed into the LFCA. This servo provides a gain of more than 80 dB at 10 Hz, with a unity gain frequency greater than 30 kHz.

The design of the photodetector is crucial to the success of this experiment. To achieve a relative intensity noise level of $10^{-9} \text{ Hz}^{-1/2}$, it is necessary to make a shot-noise-limited detection of a dc photocurrent of 300 mA with a ΔI of 300 pA/Hz^{-1/2}. The photodetector utilizes a photodiode in an ac-coupled topology instead of the standard transimpedance configuration usually used with photodiodes. Utilizing a dc transimpedance configuration would have required the use of operational amplifiers with both low-noise and high-current capabilities. Instead, it was decided to split the problem into two parts.

The bias voltage and high-current supply for the photodiode are handled by a voltage regulator. The voltage regulator is controlled by a feedback loop such that a constant reverse bias is maintained across the photodiode (see Fig. 3). This is done so that appreciable ohmic heating does not occur when the diode is run at reduced light levels.

The photocurrent is sunk across a resistor to convert the photocurrent into a voltage. The critical in-

tensity noise stabilization signal is then ac coupled at the photodiode output with a 1-Hz high-pass filter and processed by a low-noise LT1128 operational amplifier with an input-referred voltage noise of $1 \text{ nV/Hz}^{-1/2}$.

Careful consideration is also given to the effects of noise at frequencies outside the servo bandwidth. It is well known that high-frequency noise can encounter a slew of rate limits in any of the amplification stages, causing broadband noise that infects the sensitive frequency band. Although this is true throughout the servo chain, it is especially important at the front end, i.e., within the photodetector. Low-pass filtering is used extensively, at every amplification stage, providing attenuation of many orders of magnitude for signals above 100 kHz.

The photodiodes used are Hamamatsu G5832-02 2-mm diodes. These are used because of their demonstrated ability to handle fairly large power levels (with a linear response above 250 mW), as well as their high surface uniformity (with a 2% loss of sensitivity at half the distance from the diode center¹⁰). They were also measured to have a quantum efficiency of 93%.

The current best relative intensity noise level achieved by the servo is approximately $1 \times 10^{-8} \text{ Hz}^{-1/2}$ at 10 Hz and approximately $5 \times 10^{-9} \text{ Hz}^{-1/2}$ at 100 Hz (Fig. 1). This level is measured with the out-of-loop detector (see Fig. 2). The

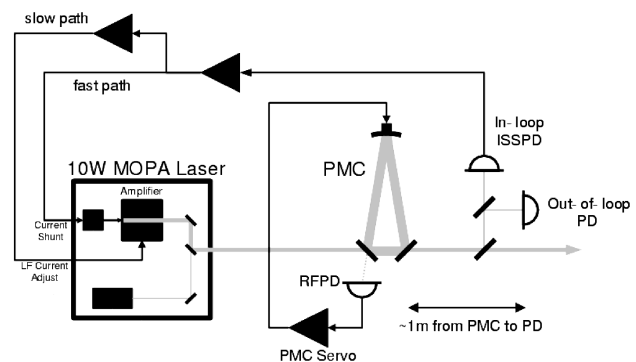

Fig. 2. Block diagram of the intensity stabilization servo. The fast path uses the fast CS actuator, whereas the slow path uses the low-bandwidth, high-range, LFCA. The control signal comes from the in-loop detector, and the out-of-loop detector is used for reference. RFPD, radio-frequency photodiode; PD, photodiode.

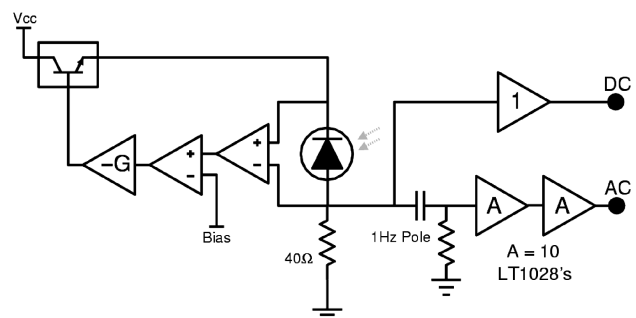

Fig. 3. Schematic of the photodiode circuit. The bias feedback control loop can be seen on the left and the preamplification on the right. 1, unity gain amplifier; G, inverting gain amplifier.

level given by the in-loop detector is artificially low since the servo loop attempts to nullify the detector's electronic noise by adding its inverse to the light.

The data in Fig. 1 were taken with a dc photocurrent of 140 mA on the out-of-loop photodetector. This corresponds to an incident light power of 175 mW. However, this relative intensity noise level can be achieved with powers as low as 100 mW.

The achieved intensity noise level is higher than the calculated shot noise level, which at 140 mA is $2 \times 10^{-9} \text{ Hz}^{-1/2}$ (see Fig. 1). At this time the limiting factor in these measurements is not known, although a candidate is the residual relative motion between the light beam and the photodiode.

Figure 1 shows that the noise floor measured by the in-loop photodiode is well below that measured by the out-of-loop diode, indicating that the achieved intensity noise is not limited by a lack of loop gain in the servo loop between 10 and 150 Hz.

Various electronic noise sources were also carefully characterized. Figure 1 shows that the measured input-referred photodetector dark noise is approximately a factor of 10 less than the measured intensity noise.

Electronic grounding noise was discovered to be a critical issue. This was not due to electromagnetic pickup but instead to problems with noise on the ground reference that were subsequently adding noise to the signal in the detector. Improvements were made over the initial measurements by sending the signals from the photodetector to the readout electronics differentially.

The light leaving the PMC is highly polarized, but further polarization filters were used to ensure that polarization jitter at the beam splitter would not cause differential intensity variations at the in-loop and out-of-loop photodiodes. To eliminate the possibility that frequency noise would be converted to intensity noise in the PMC, a frequency stabilization servo was used to reduce the frequency noise of the laser with no improvements in the intensity noise.

Finally, extensive measures were also taken to reduce the effects of any possible environmental noise sources. For instance, neutral-density filters were placed in front of the photodetectors to minimize the effects of scattered light, and the entire experiment was placed in an enclosure that significantly reduced the amount of acoustic noise and the effects of air currents, once again with minimal effect.

Further work is required to achieve the extremely demanding intensity stabilization required for the Ad-

vanced LIGO. Planned improvements include the development of in-vacuum photodetectors, moving the detectors after the LIGO suspended mode cleaner, and the use of multiple in-loop detectors.

Other researchers have observed similar performance at 100 Hz by use of a different photodetector topology.¹¹ At present it is not known what is limiting the noise performance of either experiment at this level.

In conclusion, we have achieved intensity stabilization of a solid-state laser at the $1 \times 10^{-8} \text{ Hz}^{-1/2}$ level at 10 Hz. To our knowledge this is the first time that such performance has been reported.

This research was supported by the National Science Foundation under Cooperative Agreement PHY-0107417 and LIGO Internal DCC P030072-00-R. The authors gratefully acknowledge the insightful comments on the manuscript given by David H. Shoemaker. D. Ottaway's e-mail address is ottaway@ligo.mit.edu.

References

1. B. Barish and R. Weiss, *Phys. Today* **52**(10), 44 (1999).
2. LIGO Scientific Collaboration, *Nucl. Instrum. Methods Phys. Res. A* **517**, 154 (2004).
3. K. W. Leong, N. C. Wong, and J. H. Shapiro, *Opt. Lett.* **15**, 1058 (1990).
4. T. A. Savard, K. M. O'Hara, and J. E. Thomas, *Phys. Rev. A* **56**, R1095 (1997).
5. Lightwave Electronics, Inc., MOPA Series 6000 Laser, SN #110.
6. B. Willke, "Update on Advanced LIGO PSL Program," presented at the LIGO Scientific Collaboration Meeting, Hanford, Wash. August 19–22, 2002.
7. R. W. P. Drever, J. L. Hall, F. V. Kowalski, J. Hough, G. M. Ford, A. J. Munley, and H. Ward, *Appl. Phys.* **31**, 97 (1983).
8. B. Willke, N. Uehara, E. K. Gustafson, R. L. Byer, P. J. King, S. U. Seel, and R. L. Savage, Jr., *Opt. Lett.* **23**, 1704 (1998).
9. R. S. Abbott and P. J. King, *Rev. Sci. Instrum.* **72**, 1346 (2001).
10. F. Seifert, "Entwicklung einer quantenrauschbegrenzten Leistungsstabilisierung für ein Präzisionslasersystem," Diplomarbeit (University of Hannover, Hannover, Germany, 2002).
11. B. Willke and F. Seifert, GEO600 Project, Institute for Atomic and Molecular Physics, University of Hannover, Hannover, Germany (personal communication, 2003).