

ACCEPTED VERSION

Alex Laratro, Maziar Arjomandi, Richard Kelso, Benjamin Cazzolato

A discussion of wind turbine interaction and stall contributions to wind farm noise

Journal of Wind Engineering and Industrial Aerodynamics, 2014; 127:1-10

©2014 Elsevier Ltd. All rights reserved.

[10.1016/j.jweia.2014.01.007](https://doi.org/10.1016/j.jweia.2014.01.007)

NOTICE: this is the author's version of a work that was accepted for publication in Journal of Wind Engineering and Industrial Aerodynamics. Changes resulting from the publishing process, such as peer review, editing, corrections, structural formatting, and other quality control mechanisms may not be reflected in this document. Changes may have been made to this work since it was submitted for publication. A definitive version was subsequently published in Journal of Wind Engineering and Industrial Aerodynamics, 2014; 127:1-10, [10.1016/j.jweia.2014.01.007](https://doi.org/10.1016/j.jweia.2014.01.007)

Source:

<http://www.elsevier.com/journal-authors/policies/open-access-policies/article-posting-policy>

Elsevier's Policy: An author may use the preprint for personal use, internal institutional use and for permitted scholarly posting.

...

Elsevier's AAM Policy: Authors retain the right to use the accepted author manuscript for personal use, internal institutional use and for permitted scholarly posting provided that these are not for purposes of commercial use or systematic distribution.

Elsevier believes that individual authors should be able to distribute their AAMs for their personal voluntary needs and interests, e.g. posting to their websites or their institution's repository, e-mailing to colleagues. However, our policies differ regarding the systematic aggregation or distribution of AAMs to ensure the sustainability of the journals to which AAMs are submitted. Therefore, deposit in, or posting to, subject-oriented or centralized repositories (such as PubMed Central), or institutional repositories with systematic posting mandates is permitted only under specific agreements between Elsevier and the repository, agency or institution, and only consistent with the publisher's policies concerning such repositories. Voluntary posting of AAMs in the arXiv subject repository is permitted.

...

Permitted scholarly posting: Voluntary posting by an author on open websites operated by the author or the author's institution for scholarly purposes, as determined by the author, or (in connection with preprints) on preprint servers.

April 1, 2015

<http://hdl.handle.net/2440/86551>

A discussion of wind turbine interaction and stall contributions to wind farm noise

Alex Laratro^{a*}, Maziar Arjomandi^a, Richard Kelso^a, Benjamin Cazzolato^a

School of Mechanical Engineering, The University of Adelaide, South Australia 5005, Australia

***Corresponding Author**

Tel: +61 411 039 805

E: alex.laratro@adelaide.edu.au

Keywords

Wind energy

Wind farm noise

Thumping

Turbulent inflow

Dynamic stall

Highlights

- Rotor-wake interaction plays a role in wind farm noise
- More wake data needs to be collected
- Dynamic stall noise needs to be characterised

Abstract

Wind farms have recently been reported to produce a noise signature that is described as possessing a “thumping” quality. Measurements of these signatures are limited and their effects are debated but their effect on public opinion and complaints make them a concern for researchers in this field. Proposed reasons for these noise signatures include amplitude modulation, interference patterns and wake-rotor interaction. This paper discusses these effects and concludes that wake-rotor interaction plays a role by causing variations in turbulent-inflow noise and dynamic stall. The current state of research into stall noise and wind turbine wake structure is also reviewed and it is concluded that the available information and collected data on wind turbine wake are insufficient to determine how strong this role is. More information on the velocity and turbulence fields in the wake of horizontal-axis wind turbines as well as a characterisation of the noise produced by an airfoil experiencing dynamic stall is required in order to make a full assessment of rotor-wake contributions to wind farm noise.

1. Introduction

In the past few years there has been substantial growth in the non-hydroelectric areas of the renewable energy sector, with production capacity globally increasing by 21.5% between 2011 and 2012 (Sawin 2013). Some elements of these technologies result in reduced economic viability or public acceptance which limits growth. Advancements that address these concerns, such as improvements to efficiency and better noise control, are necessary in order for rapid growth to continue.

Wind power was the fastest growing renewable in 2012, accounting for 39% of global added capacity (Sawin 2013). Given that wind speed increases with distance from the ground, larger wind turbines are constantly being developed in order to take advantage of this. A greater swept area enables more wind energy to be captured and the increase in height gives them more reliable access to high wind-speeds. Being able to access higher wind speeds more reliably increases the capacity factor of large turbines resulting in a lower levelised cost of energy compared to smaller models (Bolinger & Wiser 2012). However this increase in size can have adverse effects on the turbine's noise spectrum and its efficiency in an array configuration.

Wind turbine noise control is becoming increasingly problematic as wind turbines grow larger, as they individually emit more noise and the low frequency component of their spectrum grows (Møller & Pedersen 2011). Low frequency sound is attenuated less by the atmosphere than high frequency sound which makes large wind turbines audible from further away (ISO 9613-1:1993). There is a significant amount of negative public opinion with regards to wind turbine sound emissions due to the reported "annoying qualities" they possess. These are qualities of the sound that would increase the annoyance of wind turbine noise above that of equivalent A-weighted broadband noise level (Persson Waye & Öhrström 2002). Low-frequency sound with these qualities will therefore have a greater effect on a wider area than high-frequency noise sources. Many regulations require that an extra 5dB is added to the noise level to compensate for increased annoyance if these qualities are present (EPA South Australia 2009, NSW DPI 2011). These legal restrictions on sound pressure level/exclusion zones near residential areas encourage shorter distances between turbines in a wind farm. However close spacing creates the possibility that the wind turbines in a farm will adversely interact with each other, which can lead to unsteady blade loading, reducing power output and increasing noise level and blade fatigue (Högström et al 1988, Thomsen & Sørensen 1999). An understanding of the mechanisms of wind farm noise production is required in order to continue to comply with noise limits and understand adverse interactions between turbines in a wind farm.

Unsteady blade loads stem from variations in velocity and turbulence. Incoming wind will always possess these qualities, so wind turbines will always experience unsteady loading to some extent. Understanding how higher levels of unsteady inflow resulting from operating in the wake of another turbine affect this loading is important.

The authors posit that inflow turbulence due to wake-interaction is a significant source of noise with these reported qualities. This can manifest as periodic increases in noise level due to changes in angle-of-attack and separation effects, dynamic stall and blade-vortex interaction. Several questions need to be answered before a conclusion can be reached on this matter.

- Are large-scale turbulent structures present in the far wake of a wind turbine?
- How are the wake and its parameters affected by wind gusts?
- Will the blades of downstream turbine(s) be adversely affected by these structures?
- Will this interaction generate noise and what qualities will that noise have?

Once the answers to these questions are known whether wake-rotor interaction is contributing significantly to wind turbine noise can be determined.

Determining the loading due to unsteady flow requires definition of the flow-field, but wake structure is complicated. Due to this complexity most studies only analytically model parameters in a one-dimensional or axisymmetric fashion (Vermeer et al 2003). These simplified models are suitable for typical power prediction and layout optimisation but are too simple to properly predict unsteady loading and noise. Understanding of how the wake affects downstream turbine is greatly hindered unless computational or experimental data is used. Computational simulations often implement actuator line, actuator disc or blade element momentum models, which approximate the blades as lines or discs that apply a force to the fluid. This approach is much faster than full modelling of the blades, and suitable for most applications but occasionally insufficient. Recently large-eddy simulations (LES) of the wakes of horizontal-axis wind turbines have been conducted (Bazilevs et al. 2011, Jimenez et al 2007, Hsu et al 2013, Porté-Agel et al 2011, Sezer-Uzol & Long 2006). This is a turbulence model that directly resolves large-scale eddies and models smaller ones, eliminating the extra computational cost of simulating very small scale turbulence. There is often cross-over in these approaches, with LES studies using actuator line or disc methods (Jimenez et al 2007, Porté-Agel et al 2011). Using simplified approaches instead of modelling the blades directly may lead to missed details in the wake flow-field and airfoil noise. Differences in the approaches are largest in the near-wake, but may result in other changes in wake structure further downstream (Réthoré et al 2011). Investigations of far-wake turbulence line actuator methods are currently appropriate because such downstream differences are not known to occur in wind turbine wake simulations (Shen et al. 2012). If any discrepancies are found between the full rotor and actuator line or actuator disc models the new information can be added to these models in the form of corrections.

LES enables high fidelity simulations on a range of scales without prohibitive computational cost. Resolving structure in the velocity field in the downstream region where other turbines operate requires high fidelity models such as LES. If there is a large amount of large scale structure in the wake in this region then angle-of-attack and blade-vortex interaction effects will become significant. Changes in airfoil spectra due to these effects are understood well enough to suggest that they will increase the low frequency component of wind turbine noise. However characterisation of the noise due to dynamic stall is still required, which presents a significant challenge to determining the contribution of wake-rotor interaction.

2. Adverse wind farm noise characteristics

Most wind farm noise is broadband—that is its spectrum contains a wide range of frequencies with no large spectral peaks. While some tonal noise is produced in the mechanical components of the turbine it is drowned out by the stronger aerodynamic noise sources.

Studies into how this noise affects humans show that under certain conditions the annoyance rating by test subjects will increase. In addition the closer the subject is to the source the greater this effect becomes and a greater decrease in the ability to perform cognitive tasks occurs. Qualities of the noise such as frequency content have also been found to have an effect, with low-frequency noise being reported as more annoying (Nobbs et al 2012).

Other factors also need to be considered as visual stimuli have been found to mitigate these effects, and parameters such as turbine colour have also been weakly linked to the reported annoyance (Iachini et al 2012, Maffei et al 2013, Ruotolo et al 2012). This is of concern as many studies report that exposure to

high enough levels of noise can disturb sleep leading to increases in stress (Pedersen et al 2009). When trying to sleep there is a lack of visual stimuli which may result in disturbance from noise that is not disturbing at other times of day.

Despite these factors many residents near wind turbines report no ill-effects. In addition to this some aspects of wind turbine noise complaints suggest psychosomatic elements (Farboud et al 2013). It is not currently known whether this is the case, but as the noise signatures can vary with location it is possible that only some households are affected.

Other studies of the characteristics of wind turbine noise report complaints of subjective or descriptive measures. These studies report complaints due to qualities referred to as “swishing”, “thumping” or “throbbing” (among others), which often occur at the blade pass frequency (Oerlemans & Schepers 2009, Pedersen et al 2009, Pedersen & Persson Waye 2004, Persson Waye & Öhrström 2002, Van den Berg 2004). Characterisation of these noise qualities is hindered by the subjective and interchangeable use of the terms “throbbing”, “swishing” and “thumping” in the literature. This is due to the terms being used by residents near wind turbines to describe their experiences. Amplitude modulation, which is a periodic variation in sound level is defined by a modulation frequency (the distance between peaks) and a modulation depth (the size of the amplitude change), is considered the cause of these effects. These qualities are hard to categorise as few studies report on both the descriptors used by residents and the properties found in the noise recordings. It is likely that some, if not all, of the aforementioned characteristics stem from amplitude modulation of different noise sources but to the authors’ knowledge there is no standard quantitative definition of each descriptor.

These descriptors are useful for targeting further research into some of the poorly understood intermittent phenomena that may go unnoticed in large-scale experiments. Measurements have found that short periods of amplitude modulated noise sometimes occur at night in the signature of the Rhedes Park wind farm, as shown in Figure 1, but this variation has not been observed to this degree in a single turbine (Van den Berg 2004). Mechanisms for the production of this noise have been suggested; including velocity gradients, turbulent inflow, interference patterns and blade-tower interaction but the cause is still disputed and will be discussed further in the next section.

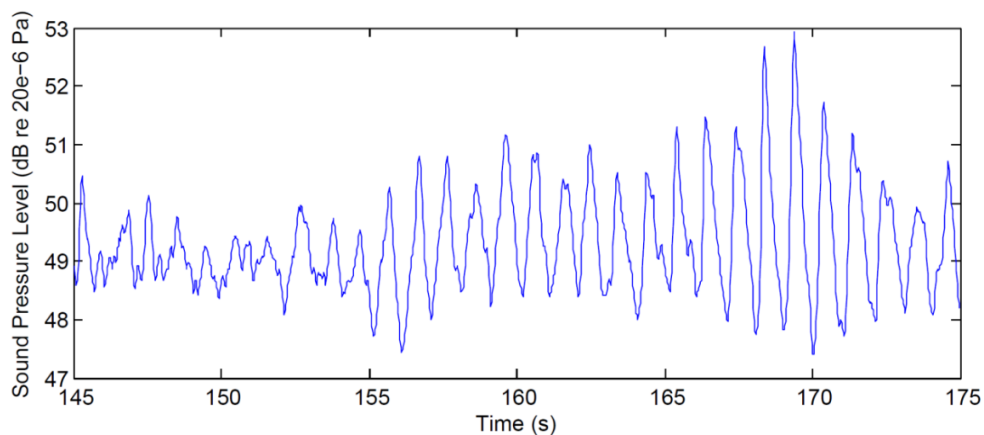

Figure 1 – Sound pressure level per 50ms due to Rhedes Park wind farm, measured at 750m from nearest turbine (adapted from Van den Berg 2004)

It is possible that the use of different descriptors in qualitative studies is due to the changes in the characteristics of amplitude modulated noise over time. Figure 2 shows a turbine spectrogram that transitions from modulated low-frequency to modulated high-frequency noise (Smith et al 2012).

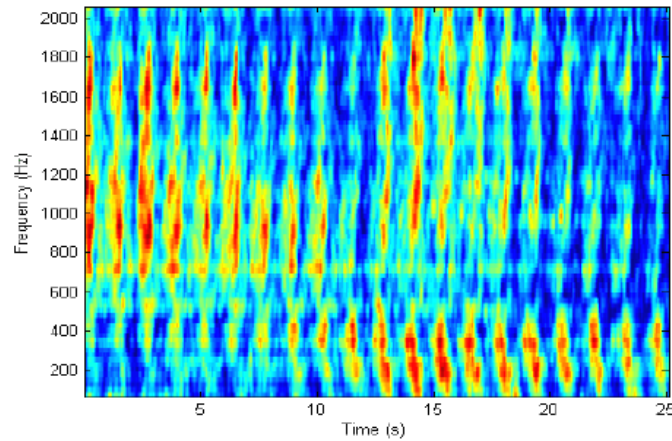

Figure 2 - Wind turbine spectrogram from 80m (Smith et al 2012)

To summarise, there are a large number of descriptors that have been used when people living near wind farms report their experiences listening to turbine noise. As they have stemmed from subjective surveys they are not yet well quantified which both hinders and assists attempts to classify the noise that people in nearby communities report as annoying. The noise cannot be properly classified from these descriptions alone but by comparing the use of these descriptors to the noise signals and atmospheric conditions at the time patterns may begin to emerge. It is likely that noise modulated by wind variability and directivity changes will result in sounds that could be described differently depending on the spectrum of the modulated noise, which can only be determined using recordings.

3. Possible noise mechanisms

There have been many reports of a “thumping” noise intermittently being produced by wind farms, but its cause is not understood (Bowdler 2008, Thorne 2011, Van den Berg 2004). It has been argued that this is due to amplitude modulation, unsteady turbulent-inflow, interference patterns, and blade-tower interaction. Due to its intermittency and similarity to the “thumping” noise emitted by helicopters unsteady turbulent-inflow is likely to be a key contributor but all of these effects are present and will play a role in forming the overall acoustic signature of the wind farm.

Turbulent-inflow noise occurs when an airfoil encounters an unsteady inflow which changes the pressure distribution across the airfoil resulting in sound (Brookes et al. 1989). The sound spectrum produced by this pressure can be predicted analytically if the energy spectrum of the incoming turbulence is known. Turbulent-inflow noise is a problem in helicopters, where the blade tip vortices interact with subsequent blades causing impulsive noise (Schlinker & Amiet 1983). This effect is called blade vortex interaction or rotor-vortex interaction noise and is responsible for giving helicopters their distinctive “blade-slap” sound during flight, which is easily discernible above the trailing-edge noise (Widnall 1971). While there are major differences in airspeed and separation distance in the case of helicopter blade-vortex interactions,

the possibility of blade-vortex interaction occurring in wind farms is not discussed in the literature. This is likely due to the lack of evidence of large-scale eddies in the far wake, as research in this area is ongoing. The authors hypothesise that this is a significant contributor to “thumping”, and a later section will focus on this source.

It has also been proposed that blade-tower interaction is responsible for “thumping” as it is in downwind turbine configurations where the rotor is situated behind the tower. Once a popular design, downwind turbines have fallen out of favour as they produce large amounts of impulsive noise during operation. As the blades pass the tower they interact with the wake vortices shed by the tower and this leads to a “thumping” noise (Kelley et al 1985). As upwind type wind turbine blades do not pass through the tower wake they do not interact with these vortices, however the tower still causes a deformation of the flow immediately upstream, which the blade does pass through and it has been proposed that this is significant enough to result in impulsive noise (Doolan et al 2012a). A study investigating the effect of the tower on unsteady blade loads found them to be insignificant compared to stochastic load variations from turbulence under most conditions (Kim et al 2011). In addition, increasing mean wind speed and yaw error leads to a larger variation in wind speed around a wind turbine rotor, which increases modulation depth. Conversely the relative levels of load fluctuations due to the tower decrease with increasing wind speed and yaw error (Kim et al 2011). This indicates that blade-tower interaction noise is lower in conditions favourable to high noise levels from other sources.

Another proposed explanation is that turbines in a wind farm are causing areas of large constructive interference (Cand et al 2011). It was thought that if the depth of amplitude modulation is large enough, amplitude-modulated noise would approach an impulsive signal which could be described as “thumping” and several studies report that “thumping” noise in horizontal axis wind turbines is most likely due to extreme instances of amplitude modulation (Bowdler 2008, Lee et al 2011). Local variations in mean wind speed results in each turbine operating at a different rotational speed, which was thought to produce variations in far-field sound pressure as they move in and out of phase, amplifying the effects of amplitude modulation (Van den Berg 2004). But this is not the case as the sound pressure level variations of two turbines being in phase will not increase modulation depth (Bowdler 2008). However being in phase will raise the average sound level, which can make qualities of the turbine noise temporarily audible at distances where they otherwise would not be (Bowdler 2008). Because of this the role of interference should not be completely dismissed.

Similarly the role of sound propagation cannot be overlooked. Lower frequency sound, which as stated previously may be perceived as annoying, travels further than higher frequencies and will increase in dominance over distance. In addition velocity or temperature gradients result in refraction of noise which can lead to changes in audible distance (Cummings 2013). When downwind of a turbine the sound refracts downwards and reflects off of the ground. This refraction is pronounced at low frequencies, with 8Hz sound levels at 5000m reaching up to 20dB higher than expected for spherical spreading (Willshire 1985). A temperature inversion, where the temperature at ground level is lower than the temperature higher in the atmosphere, also causes downward refraction of sound and will lead to similar effects. This indicates that wind turbine noise will in general propagate further at night, when temperature inversion is a common occurrence. The properties of the ground also affect the sound propagation, as acoustic impedance changes both the reflection coefficient and phase change at reflection. As such noise will propagate further over acoustically harder ground, where more of the noise is reflected. ISO 9613 suggests that farmland and similar terrain, where wind turbines are most often situated should be considered acoustically soft, however field measurements have found that this under-predicts noise levels at 500m (ISO 9613-1:1993, Plovsing & Søndergaard 2011). Additionally in Australia the grass around farmland is dry in summer and often short due to grazing, which will increase its acoustic hardness.

Smaller scale effects will also result in changes in the sound. This difficulty in predicting noise propagation is amplified by the presence of complex terrain, as it will obstruct and reflect sound, as well as introducing changes to the local flow and temperature field which further affect how the sound will propagate (Kaliski et al 2011). This may be contributing to the audibility of adverse noise qualities but it is unlikely that variations in propagation are coherent enough to cause the “thumping” signatures themselves.

In summary while the cause of these characteristics is disputed some potential causes are more probable explanations. Interference patterns and other propagation effects may make low frequency amplitude modulation patterns more audible, but this requires an existing signature, the cause of which is still unknown. Helicopters produce similar noise signatures due to the interaction between the rotor and the blade tip vortices and this sound is audible over the trailing edge noise. Determining whether this could occur in horizontal-axis wind turbines requires knowledge of the structure of the wake downstream turbines are operating in and the amount of noise produced by these events. This discussion focuses on effects due to rotor-wake interaction, which included amplitude modulation of turbulent inflow noise, blade-vortex interaction and dynamic stall.

4. Wake structure and propagation

In order to best predict loading and noise on wind turbine blades the following parameters are required in the plane of the rotor

- Velocity
- x, y and z turbulence intensities
- Turbulence energy spectrum
- Turbulence length scale

This is problematic when investigating wake operation as existing studies of horizontal axis wind turbine wakes have a different focuses or use simplifications that can disrupt the wake structure. For example most wind turbine wake research focuses on the magnitude of the axial velocity deficit and the magnitude of turbulent intensity as these are the parameters that most influence power output (Chamorro & Porté-Agel 2009). Additionally, wake parameters are often reported as one-dimensional averages or axisymmetric distributions, which render them useless for determining how blade loading changes during a revolution.

The study of wind turbine wake structure has been focused on experimental and numerical investigations. Wind tunnel testing is more controlled than field experiments, giving a faster turnaround and better resolution and characterisation of inflow. Field experiments are preferable however, as it is not known how much of an effect flow confinement has on wind turbine wake structure. Computational models are also valuable as they produce finer data sets, but they are difficult to produce and the other methods are still required for validation.

Experimental measurements of the structure of the flow field are mostly concentrated on the near wake, which only extends a few rotor diameters downstream due to the costs associated with large scale experiments. Typically wind farms have a turbine spacing of approximately 7-10 rotor diameters and so the wake structure at this distance is of interest (Ahmed 2011, Hirth & Schroeder 2013, Meyers & Meneveau 2012). One of the most comprehensive wind tunnel tests of a horizontal-axis wind turbine was performed by the National Research Energy Laboratory (NREL) and gathered very little far wake data

(Simms et al 2001). Concentrating on the near wake enables the helical vortices shed from the blade tips to be resolved with smoke probes and studied as shown in Figure 3. In the far wake these vortices break down, and the smoke trails do not yield much useful data. Some experiments have been conducted using particle image velocimetry but these are also currently focused on near-wake measurements (Vermeer et al 2003). Wind tunnel tests have also been performed to show the effects of the tower on wake development, but measurements across the whole turbine were not taken (Nygard 2011).

Field experiments have similarly not been conducive to determining the significance of wake-rotor interaction. A turbulence cross-section in the near wake (at 2 rotor diameters) of a full-scale turbine has been captured using SODAR, but further work was hampered by variability in the wind direction (Högström et al 1988). Most studies focus on the distribution of parameters in vertical lines at various stations behind the tower, which is a limitation currently shared by many reports detailing computational models.



Figure 3– NREL Phase IV experiment with smoke trail (Hand 2001)

Computational models to investigate the structure of wind turbine wakes are also lacking in number and detail. Many large-eddy simulation (LES) simulations do not model the area of the wake in which other turbines operate (Bazilevs et al. 2011, Hsu et al 2013, Sezer-Uzol & Long 2006). Actuator disc models which model the rotor as a porous disc are often used but these simplifications can result in the loss of the desired accuracy (Norris et al 2010). When investigating wake structure, actuator line, actuator surface or full-rotor models should be used where possible, as they capture some details of the flow that actuator disc models may not. Some models have used larger domains but the region of interest is still close to the exit (at approximately 10 rotor diameters) which may affect the results (Troldborg et al 2010). These studies can still provide other useful information about the formation of the far wake. Vorticity isosurfaces reveal that as wind speed increases the helical tip vortices break down at larger downstream distances. At a free-stream speed of 10m/s the tip vortices have only just broken down at 7 rotor diameters (7D) as shown in Figure 4. Other simulations used sufficiently large domains but reported data in a longitudinal plane, which does not give much information about wake structure (Jimenez et al 2007, Porté-Agel et al 2011, Zahle & Sørensen 2007). However when using longitudinal data the turbulence intensity can be still be seen to change at least 3% across the rotor at 7 rotor diameters in wind tunnel measurements, indicating some level of increased unsteady loading (Porté-Agel et al 2011).

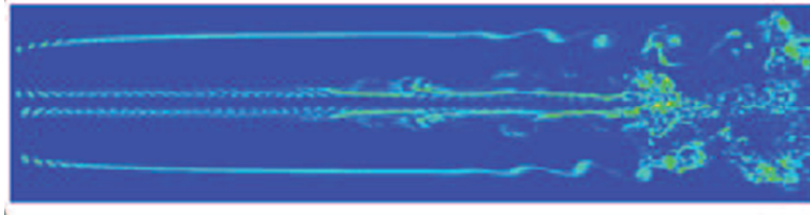

Figure 4- Vorticity isosurfaces in horizontal plane (Troldborg et al 2010)

A recent large-eddy simulation of the NREL experiment observed that after the collapse of the helical tip vortices, large stream-wise vortices were formed, as shown in Figure 5 (Mo et al 2013). The regions containing these vortices also contained most of the vorticity and turbulence intensity in the region indicating they are the main source of unsteady loading.

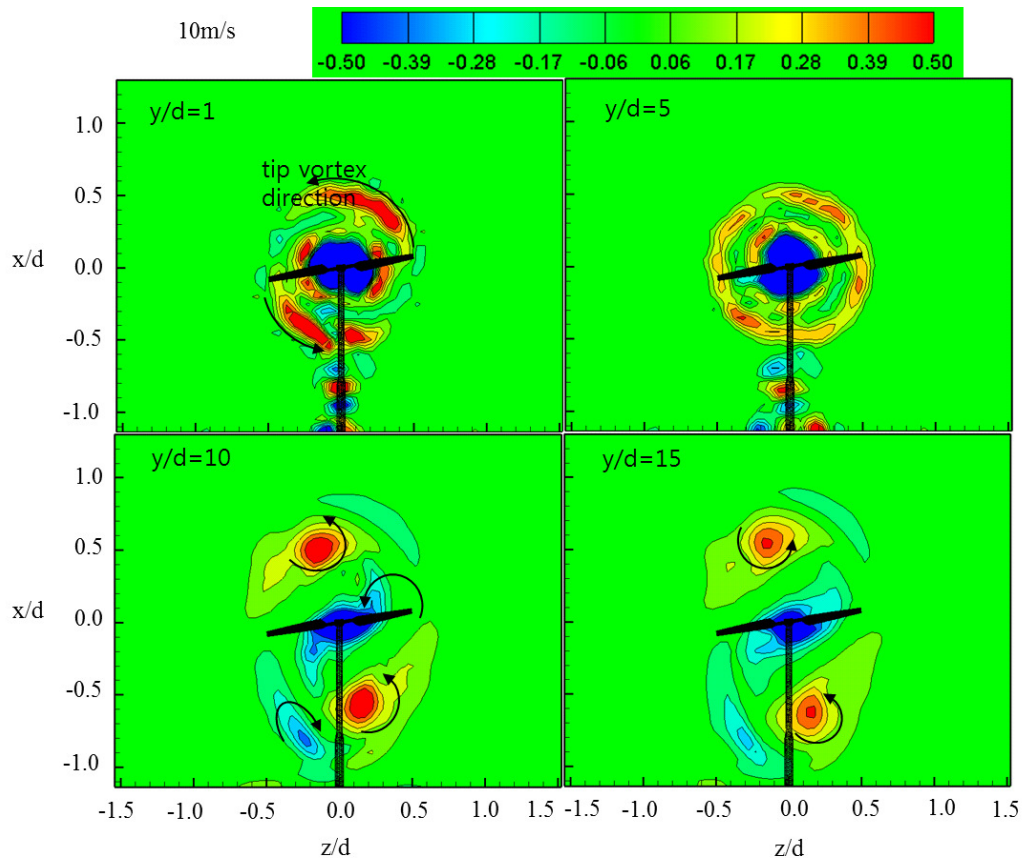

Figure 5– Simulated wake vortices in NREL experiment (adapted from Mo et al 2013)

How the wakes of turbines in a wind farm interact must also be considered. Full rotor simulations of wind farms are not common due to the size of the domain that must be considered resulting in an impractical computational cost for little benefit. Actuator-disc/line or analytical methods are more common as are wind tunnel experiments with the choice of method depending on application (Christiansen & Hasager

2005, Frandsen et al 2006). For systems larger than two turbines, analytical models are often used, and while these are adequate for optimising a wind farm layout for power output, they cannot give insight into how the flow structure is affected as each turbine interacts with the combined wakes of the upstream turbines. Experiments performed on scale wind farms yield some useful information about the flow but are limited by the data that can be collected (Lebrón et al 2010). Some studies have been conducted using line-actuators and periodic boundary conditions and these show the velocity deficit and turbulence increasing due to each row of turbines (Sørensen et al 2007). Most of these are focused on the velocity deficit behind the turbines and report little or one-dimensional information about the turbulence or vorticity in the wake.

In a simulation of a tandem wind turbine system, it has been found that the turbulence in the incoming wind has a large effect on the system's wake structure, with high incoming turbulence resulting in the downstream rotor ingesting still higher levels of turbulence, and its wake in turn breaking down closer to the turbine (Troldborg et al 2011). This results in smaller scale turbulent structures for downstream turbines, which may reduce the generated turbulent inflow noise (Troldborg et al 2011). However if two turbines are laterally offset and turbulence is low then ingesting the upstream turbine wake results in an asymmetric near-wake with high levels of turbulence on the side of the upstream turbine and a flow still dominated by tip vortex structures on the other, which may contribute to variation in noise level over time (Chamorro & Arndt 2011, Troldborg et al 2011).

Upon comparing several studies it is apparent that simulations of the wakes of horizontal-axis wind turbines vary with modelling, conditions and turbine design. Common elements are present however, the most notable of which is a series of helical tip vortices which break down further downstream. A recent simulation suggests the existence of large stream-wise vortices downstream but more simulations and experiments are needed in order to confirm the existence of large-scale coherent vortices in the far wake. In addition to this, the large effects that placing wind turbines in an array can have on their respective wakes means that structures found in the wake of a single turbine may only be applicable to some turbines in an array or none at all. Once the properties of horizontal-axis wind turbine wakes are more defined the effect that operating in the wake has on turbine noise can be assessed.

5. Turbulent-inflow noise

Turbulent-inflow noise is a form of aerodynamic noise that arises when an airfoil encounters an unsteady flow. It is characterised by its low-frequency dominant spectra and dipole-like directivity pattern. The production of large amounts of turbulent-inflow noise will contribute to wind turbine noise at large distances as it is dominated by low frequencies. Blade-vortex interaction is a related effect that is of some concern. However it seems likely that if it occurs it will not do so under ideal conditions and is likely to be insignificant compared to more general turbulent-inflow effects.

When an airfoil encounters unsteady flow there is a transient disruption to its surface pressure, resulting in a change in lift and noise signature. This noise is known as turbulent-inflow noise and it is responsible for giving helicopters their distinctive sound (Widnall 1971). It is usually predicted using analytical models since simulations of aerofoil noise require extremely fine spatial and temporal resolution along the sound's path in order to resolve the spectrum. Analytically predicting the spectrum due to turbulent inflow requires, at a minimum, the distributions of turbulent length scale and intensity, but is most accurate if the turbulent energy spectrum is used.

Analytical work describing how vortices and turbulence affect airfoil noise was pioneered by Amiet using a model that was originally applied to rotor-vortex interaction in helicopters but still sees widespread use for more general applications (Amiet 1975, 1978, 1986). The model determines the surface pressure fluctuations using the airfoil's lift response and the turbulent energy spectrum normal to the blade and these fluctuations are then propagated to the far-field as sound. It uses a large aspect-ratio, thin airfoil approximation, and while corrections for airfoil shape, thickness and backscattering have been developed they are not yet widely implemented (Moriarty et al 2005, Roger & Moreau 2005, Zhu et al 2005). Predicted and experimental spectrum differ by less than 6dB for frequencies below 1.5kHz, above this however the accuracy of the model appears to decline rapidly (Amiet 1975, Schlinker & Amiet 1983).

Using Amiet's model and an appropriate turbulent energy spectrum, equations can be produced that relate turbulence intensity, turbulence length scale and airfoil geometry to third-octave spectrum. This is mostly performed using the Von Karman turbulent energy spectrum, as this is a good approximation to atmospheric turbulence. It has been shown that if the turbulence is non-uniform then the turbulence field can be discretised to yield results that also agree with experiment to within about 3dB until 1500Hz (Doolan et al 2012b). Results are further expected to improve if the actual energy spectrum of the turbulence can be measured—especially if the assumption of Von Karman turbulence is not valid. Amiet's model is also used predict to the spectrum of blade-vortex interaction (Schlinker & Amiet 1983). Using this technique the turbulent-inflow noise due to operating in a wind turbine wake can be determined if the turbulence spectrum or intensity and length scale are known.

Blade-vortex interactions are a subset of inflow turbulence noise that are of some concern due to the possibility of vortices in the wake. These interactions are divided into parallel, oblique and perpendicular configurations, describing the angle of the vortex line in the chordal plane of the airfoil. Parallel and perpendicular configurations are when this angle (referred to as the rotor-plane angle in the context of helicopters) is 0° and 90° respectively. The other main orientation parameters are the shaft-plane angle and the miss distance which are shown in Figure 6.

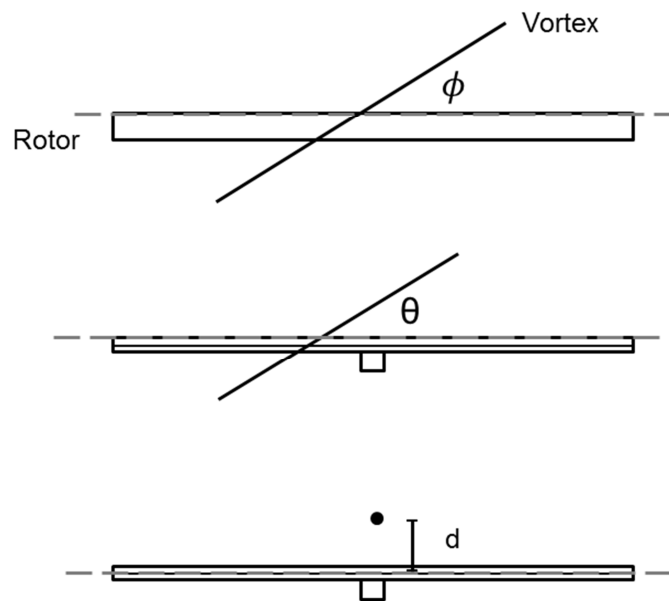

Figure 6 - Vortex orientation parameters. ϕ : rotor-plane angle, θ : shaft-plane angle, d : miss distance

Beyond the initial studies little experimental parameterisation of blade-vortex interaction noise has been performed. Sensitivity analyses of blade-vortex interaction noise have instead been performed by calculating spectra using the existing model (Gallman 1994, Malovrh & Gandhi 2005). Increases in circulation strength, which is proportional to both the tangential velocity and radius, increase noise levels, but when radius is increased noise levels decrease (Gallman 1994). This suggests that changing the peak tangential velocity has a greater effect on the noise than the radius. Increases in local Mach number also found increase in generated noise levels (Malovrh & Gandhi 2005). Parallel interactions are the loudest due to maximising the affected area, and perpendicular interactions are the quietest (Malovrh & Gandhi 2005). Increasing the angle between the chord plane and the vortex line also reduces noise level, as does increasing the perpendicular distance between vortex line and chord plane (Gallman 1994, Malovrh & Gandhi 2005). The effects of changing these parameters is summarised in Table 1. Loud interactions therefore occur when a small, strong vortex undergoes a parallel interaction with an airfoil in high Mach number flow. This indicates that large, stream-wise vortices are unlikely to contribute much to wind turbine sound level through blade-vortex interaction.

Table 1 – Summary of blade-vortex interaction parameters

	Change in parameter	Noise level
Circulation strength	Increasing	Increasing
Core radius	Increasing	Decreasing
Rotor-plane angle	Towards 0°	Increasing
Shaft-plane angle	Towards 0°	Increasing
Miss distance	Increasing	Decreasing
Mach number	Increasing	Increasing

In summary it is possible to predict the noise due to blade-vortex interaction if the spectrum of the incoming turbulence is known. If the spectrum is not known then the turbulence can be assumed isotropic and a grid of turbulence intensities can be used to estimate the noise level. Interaction with wake vortices also generates noise, but current wake structure research indicates that if vortices are formed they will interact in a way that is unfavourable for loud noise generation. However interaction with vortices can result in local variations in angle-of-attack, which is another avenue that must be explored to determine the extent to which wake interaction affects wind farms.

6. Changes in angle-of-attack and directivity

In addition to inflow turbulence noise, non-uniform flow can affect noise due to changes in the angle-of-attack and directivity. Changes in the angle-of-attack modify the overall sound level, whereas changes in directivity result in the largest portion of sound power radiating to different locations at different points during a cycle. Large angle of attack variations can also result in the blades experiencing stall, which is likely to further increase sound levels through boundary layer growth and vortex shedding.

Non-uniform velocity and turbulence intensity across a wind turbine rotor result in the blades experiencing a different angle of attack at different points of the cycle. The distribution of angles of attack will indicate how each section of the airfoil will behave during a cycle. Figure 7 shows that it is possible to predict the changes in angle-of-attack due to wind shear; factors m and n are the vertical and lateral wind shear

exponents respectively. As the flow field in the wake of a horizontal-axis wind turbine is not currently well defined, true angle-of-attack distributions have not been produced.

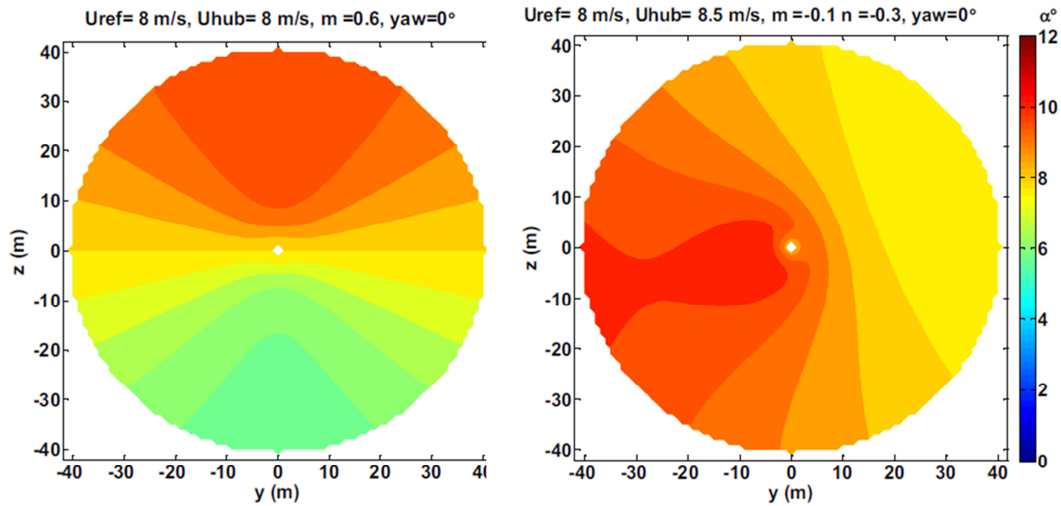

Figure 7 – Estimated variation in angle of attack due to wind shear; vertical (left) and combined horizontal and vertical (right) (Smith et al 2012)

It is evident that operating an airfoil at different angles of attack results in variation in boundary layer thickness at the trailing edge which in turn produces a variation in noise level. As the thickness of the boundary layer and the trailing edge increases with angle-of-attack so does the overall noise level of the airfoil (Brookes et al. 1989). Dynamic stall will also result if the angle-of-attack variation is large and frequent enough and this is likely to cause further increases in noise level as large eddies are formed and subsequently collapse which will be discussed in the next section.

Changes in directivity have been proposed as an additional factor in far-field low-frequency noise (Smith et al 2012). Noise due to separation or turbulent-inflow has dipole directivity which makes it strongest normal to the airfoil. In contrast, trailing edge noise directivity is cardioid-like — strongest diagonally forward of the leading edge as shown in Figure 8 (Oerlemans & Schepers 2009). A change from low-frequency dominant to high-frequency dominant noise will result in a change in directivity of the overall blade turbine noise as shown in Figure 9. It has been suggested that this results in turbulent-inflow and separation noise being more prominent normal to the rotor plane (Lee et al 2011).

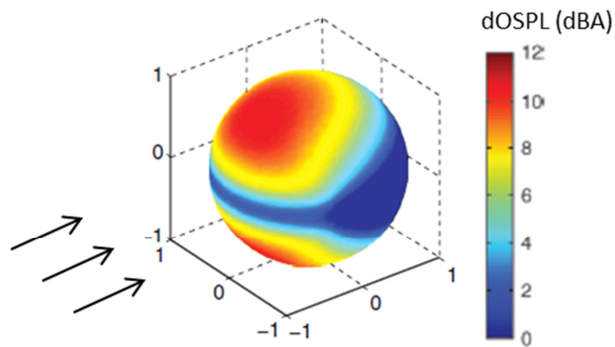

Figure 8 – Trailing-edge noise directivity (adapted from Oerlemans & Schepers 2009)

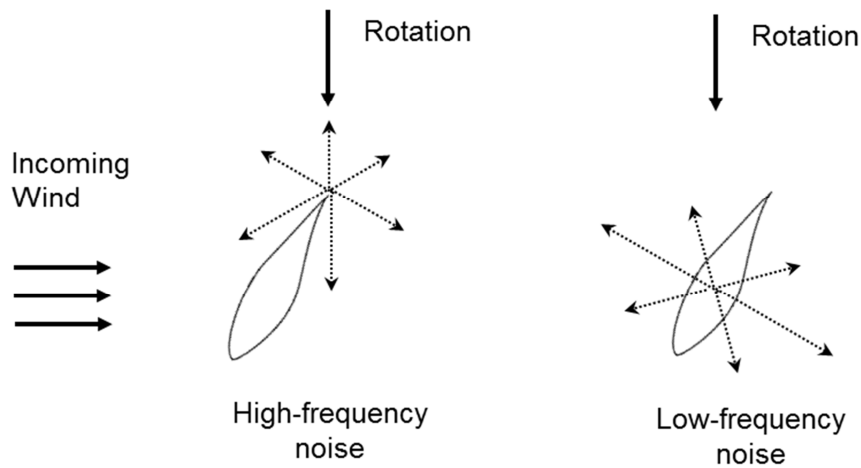

Figure 9 – Change in directivity with noise frequency

As previously mentioned, much of the trailing edge noise is then directed into the atmosphere on the upstroke and the ground on the downstroke. Sound in the atmosphere is also refracted depending on the temperature and wind speed gradient. The speed of sound decreases with temperature and thus distance from the ground (on a warm day), upwind sound is refracted upwards and downwind sound may be refracted upwards or downwards (Bies & Hansen 2003). It has been suggested that these effects result in a decreased contribution from trailing-edge noise to far-field measurements (Smith et al 2012). It is difficult to correlate these predicted directivities of wind turbine noise with complaints due to a lack of data regarding the observer's locations and the wind direction at the time of complaint. This data should be more often reported in future to assist in determining if these effects are responsible for complaints.

In summary, as a wind turbine blade undergoes each revolution it is subjected to a cyclic variation in angle of attack. High angles of attack result in increased noise levels due to louder trailing-edge noise and subsequently the occurrence of stall. In addition, as the spectrum transitions from trailing-edge noise dominated to stall and turbulent-inflow noise dominated there is a change in directivity. When trailing-edge noise dominates, the noise is directed approximately in the direction of blade movement. When stall and turbulent-inflow noise dominate, the noise is directed orthogonal to the rotor plane. Correlating this

with noise complaints is difficult due to lack of data. Combinations of amplitude and directivity variations can lead to amplitude modulation, depending on the level of non-uniform flow and ground temperature.

7. Dynamic stall noise

Airfoils experience dynamic stall when they are subjected to a large and rapid variation in angle of attack. This results in the formation of large vortices which increase the unsteady loads on the airfoil followed by a drop into deep stall (McCroskey 1981). It is thought that these vortices may also result in increased noise generation but while current dynamic stall models can predict their size they are insufficient to predict finer details.

Dynamic stall is a major source of unsteady loading on horizontal-axis wind turbines. Under normal operational conditions dynamic stall can occur on up to half the cycles of a turbine (Shiple et al 1995). The occurrence of dynamic stall is dependent on span-wise location, free-stream velocity, yaw error, as well as tilting and coning of the rotor. Of these, highly yawed flow is the major contributor to the occurrence of dynamic stall (Shiple et al 1995). Increases in unsteady inflow due to operation in the wake of another turbine are thought to increase the probability of dynamic stall (Choudhry et al 2012). This increase in dynamic stall occurrence will change the noise signature of the turbine and may contribute to complaints.

The properties of dynamic stall are affected by the Reynolds number and the reduced frequency ($k = c\Omega/2U$) — where c is the airfoil chord (m), Ω is the oscillation frequency (rad/s) and U is the fluid velocity (m/s). These parameters affect the strength of vortex shedding and lift hysteresis as shown in Table 2.

Table 2 – Influence of parameters on dynamic stall (adapted from McCroskey et al 1976)

	Reynolds Number	Oscillation amplitude	Reduced frequency	Leading edge geometry
Effect on vortex shedding	Negligible	Major in isolated cases	Small	Moderate
Effect on lift	Small	Major in isolated cases	Major	Major
Boundary layer separation	Small	Moderate	Major	Major

Figure 10 shows a comparison of the reduced frequency along the blade between the NREL turbine and some large scale turbines. As many commercial turbines use a simplified version of the optimal chord vs span-wise location curve these can be taken as representative of large-scale turbines. The curve shows that for the large turbines approximately half the blade is in the unsteady flow regime ($k > 0.05$), above which unsteady flow effects cannot be neglected. This indicates that these regions of the blade are susceptible to dynamic stall if angle of attack variations are large enough. This reduced frequency will increase further if the blade is experiencing unsteady inflow from other sources.

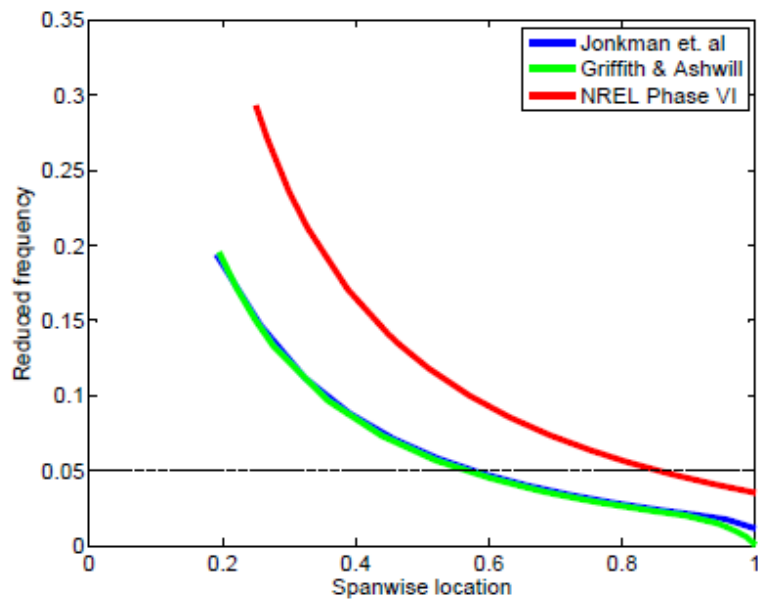

Figure 10 - Reduced frequency k vs span-wise location for several turbine blades

Detailed analysis of the flow field when dynamic stall occurs is restricted to experimental data and computational models. Existing semi-empirical models are limited to predicting the variation in aerodynamic coefficients with angle of attack (Holierhoek 2013, Leishman 2002). Some models—such as the Leishman-Beddoes model— explicitly account for the formation and shedding of the dynamic stall vortex but cannot be used to predict the structure of the vortex. Semi-empirical models of dynamic stall are therefore currently unsuitable for acoustic predictions.

To the authors' knowledge noise measurements have not been made on an airfoil experiencing dynamic stall. Some papers reporting on computational simulations suggest that their models could be adapted to predict the spectrum, but this has not been performed. Despite this there is sufficient information about similar phenomenon to make some predictions about the nature of noise produced during dynamic stall.

From experiments on stall it is known that the onset of vortex shedding will increase the amplitude of the main spectral peak as shown in Figure 11 (Moreau et al 2009). As the angle-of-attack grows the main peak also shifts to slightly lower frequencies as vortex shedding begins to occur (Moreau et al 2009). Experiments on flat-plates and axial fans have shown similar spectral peaks at the during vortex shedding (Longhouse 1977, Roger et 2006).

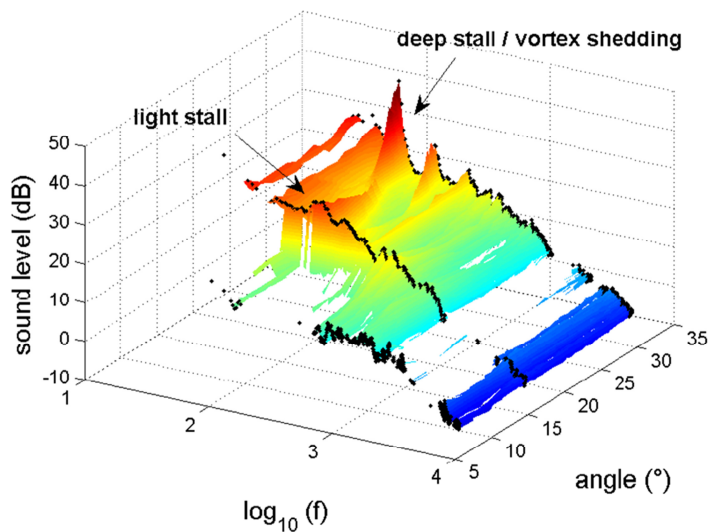

Figure 11 - Noise due to stall on a NACA 0012 airfoil at $Re \sim 1.5 \times 10^5$ (Moreau et al 2009)

Noise is also produced when counter-rotating vortices interact. Direct numerical simulation of interacting vortex pairs has shown that a large pulse of acoustic pressure is produced when two vortices interact, followed by a period of less intense noise (Zhang 2013). This indicates that dynamic stall noise may have a periodic impulsive component due to interaction between vortices shed from the leading and trailing edge.

Dynamic stall flow features are dominated by large vortices which are shed from the leading and trailing edge and interact as they move downstream. Vortex shedding and interaction are both sources of low frequency noise and so dynamic stall events are likely to have similar spectra. More research into dynamic stall is required in order to determine the extent to which wind farms may be affected by this noise, but the authors hypothesise that large amounts of turbulent inflow noise and dynamic stall due to wake operation are the primary source of “thumping” noise.

8. Discussion and Conclusion

Wind turbines in wind farms have been seen to produce rapidly varying noise levels, which are not well understood. Reasons that have been proposed to explain this include:

- Amplitude modulation of trailing-edge noise due to wind gradients and changes in directivity
- Amplitude modulation of turbulent-inflow noise due to the wake of upstream turbines
- Turbulent inflow noise changes due to wind gusts
- Dynamic stall noise due to unsteady inflow
- Blade-vortex interaction noise
- Interference patterns from multiple turbines
- Atmospheric refraction and frequency-dependent attenuation

- Interaction between the blades and upstream deformation from the tower

These effects are all present in wind farms but it is currently unclear to what extent they contribute to the overall noise signatures. Interference patterns may increase the overall noise level but not the depth of modulation and atmospheric effects will filter out some frequencies. This may amplify existing noise signatures but it does not provide an explanation for their root cause. Blade-tower interaction can also occur in single turbines where these noise patterns are not observed and so it is likely not the cause of the “thumping” patterns. Due to lack of consistency in measurements even the existence of disturbances due to wind turbine noise is disputed. Measurement and simulation of horizontal-axis wind turbine wakes is currently underdeveloped with regard to this application and cannot provide enough insight into flow structure to determine the strength of these effects. Turbulent-inflow noise depends on the size, strength and orientation of wake vortices. Large changes in angle of attack due to non-uniformities in the flow field result in dynamic stall which increases noise level due to vortex shedding and collapse. High fidelity simulations of wind turbine wake development are required in order to determine the extent to which these phenomena contribute to noise level. More experimental measurements of wind turbine wake flow fields are also needed to compare with simulations.

Records of the noise produced during dynamic stall have not been published, but it can be inferred from prior research into noise due to vortex shedding and stall that the noise during dynamic stall will likely be louder than during normal operation. Due to the large surface pressure fluctuations and vortex shedding during dynamic stall it is likely that there will be an increase in noise level over normal operation. Unsteady flow affects the noise signature in horizontal-axis wind turbines and with more research, the significance of these noise sources can be determined.

Acknowledgements

The authors would like to thank Sophie Hollitt and Amelia Thomas for their contributions to editing.

References

- Ahmed, S., 2011. *Wind Energy: Theory and Practice*. PHI Learning Pvt. Ltd., New Dehli, India
- Amiet, R.K., 1975. Acoustic radiation from an airfoil in a turbulent stream. *Journal of Sound and Vibration* 41, 407–420
- Amiet, R.K., 1978. Noise due to rotor-turbulence interaction. *NASA Conference Publication 2052*, 109–126
- Amiet, R.K., 1986. Airfoil gust response and the sound produced by airfoil-vortex interaction. *Journal of Sound and Vibration* 107, 487–506
- Bazilevs, Y., Hsu, M-C., Akkerman, I., Wright, S., Takizawa, K., Henicke, B., Spielman, T., Tezduyar, T.E., 2011. 3D simulation of wind turbine rotors at full scale. Part I: Geometry modeling and aerodynamics. *International Journal for Numerical Methods in Fluids* 65, 207–235
- Bies, D., Hansen, C., 2003. *Engineering noise control: Theory and practice*. 3rd edition, Taylor & Francis, New York, United States
- Bolinger, M., Wiser, R., 2012, Understanding wind turbine price trends in the US over the past decade. *Energy Policy* 42, 628–641
- Bowdler, D., 2008. Amplitude modulation of wind turbine noise: A review of the evidence. *Institute of Acoustics Bulletin* 33, 31–41
- Brooks, T.F., Pope, D.S., Marcolini, M.A, 1989. *Airfoil self-noise and prediction*. National Aeronautics and Space Administration, Scientific and Technical Information, Hampton, United States
- Cand, M., Bullmore, A., Smith, M., Von-Hunerbein, S., Davis, R., 2011. Wind turbine amplitude modulation: research to improve understanding as to its cause & effect. In *Proceedings of Wind Turbine Noise 2011*
- Chamorro, L.P., Porté-Agel, F., 2009. A wind-tunnel investigation of wind-turbine wakes: boundary-layer turbulence effects. *Boundary-layer Meteorology* 132, 129–149
- Chamorro, L.P., Arndt, R.E.A., 2011. Turbulent flow properties around a staggered wind farm. *Boundary-layer Meteorology* 141, 349-367
- Choudhry, A., Mo, J-O., Arjomandi, M., Kelso, R., 2012. Effects of spacing between wind turbines on blade dynamic stall. *Australasian Fluid Mechanics Conference 2012*
- Christiansen, M.B., Hasager, C.B., 2005. Wake effects of large offshore wind farms identified from satellite SAR. *Remote Sensing of Environment* 98, 251-268
- Cummings, J., 2013. The variability factor in wind turbine noise. *5th International Conference on Wind Turbine Noise*
- Doolan, C., Moreau, D.J., Brooks, L.A., 2012a. Wind turbine noise mechanisms and some concepts for its control. *Acoustics Australia* 40, 7–13
- Doolan, C.J., Coombs, J.L, Moreau, D.J., Zander, A.C., Brooks, L.A, 2012b. Prediction of noise from a wing-in-junction flow using computational fluid dynamics. *Proceedings of Acoustics 2012 - Fremantle*
- EPA South Australia, 2009. Wind farms environmental noise guidelines. EPA South Australia, Adelaide, Australia
- Gallman, J.M., 1994. Parametric computational study of isolated blade-vortex interaction noise. *AIAA Journal* 32, 232–238
- Farboud, A., Crunkhorn, R., Trinidad, A, 2013. 'Wind turbine syndrome': fact or fiction?, *The Journal of Laryngology & Otology* 127. 222-226
- Frandsen, S., Barthelmie, R., Pryor, S., Rathmann, O., Larsen, S., Højstrup, J., Thøgersen, M., 2006. Analytical modelling of wind speed deficit in large offshore wind farms. *Wind Energy* 9, 39-53
- Hand, M., 2001. *Unsteady aerodynamics experiment phase VI: Wind tunnel test configurations and available data campaigns*. National Renewable Energy Laboratory, Golden, United States

- Hirth, B.D., Schroeder, J.L., 2013. Documenting wind speed and power deficits behind a utility-scale wind turbine. *Journal of Applied Meteorology and Climatology* 52, 39–46
- Högström, U., Asimakopoulos, D.N., Kambezidis, H., Helmis, C.G., Smedman, A., 1988. A field study of the wake behind a 2 mw wind turbine. *Atmospheric Environment (1967)* 22, 803–820
- Holierhoek, J.G., De Vaal, J.B., Van Zuijlen, A.H., Bijl, H., 2013. Comparing different dynamic stall models. *Wind Energy* 16, 139–158
- Hsu, M-C., Akkerman, I., Bazilevs, Y., 2013. Finite element simulation of wind turbine aerodynamics: Validation study using NREL phase VI experiment. *Wind Energy*. (Accepted for publication)
- Iachini, T., Maffei, L., Ruotolo, F., Senese, V.P., Ruggiero, G., Masullo, M., Alekseeva, N., 2012. Multisensory assessment of acoustic comfort aboard metros: a virtual reality study. *Applied Cognitive Psychology* 26, 757-767
- ISO 9613–1:1993. Acoustics -- Attenuation of sound during propagation outdoors. Part 1: Calculation of the absorption of sound by the atmosphere. ISO, Geneva, Switzerland
- Jimenez, A., Crespo, A., Migoya, E., Garcia, J., 2007. Advances in large-eddy simulation of a wind turbine wake. *Journal of Physics: Conference Series* 75
- Kaliski, K., Duncan, E., 2008. Propagation modelling parameters for wind power projects. *Sound and Vibration* 42, no. 12, 12-15
- Kaliski, K., Duncan, E., Wilson, D.K., Vecherin, S., 2011. Improving predictions of wind turbine noise using PE modeling. In *INTER-NOISE and NOISE-CON Congress and Conference Proceedings 2011*, 371-383
- Kelley, N.D., McKenna, H.E., Hemphill, R.R., Etter, C.L., Garrelts, R.L., Linn N.C., 1985. Acoustic noise associated with the MOD-1 wind turbine: its source, impact, and control. Solar Energy Research Institute, Golden, United States
- Kim, H., Lee, S., Lee, S., 2011. Influence of blade-tower interaction in upwind-type horizontal axis wind turbines on aerodynamics. *Journal of Mechanical Science and Technology* 25, 1351–1360
- Lebrón, J., Cal, R.B., Kang, H., Castillo, L., Meneveau, C., 2009. Interaction between a wind turbine array and a turbulent boundary layer. In *11th Americas Conference on Wind Engineering*.
- Lee, S., Kim, K., Choi, W., Lee, S., 2011. Annoyance caused by amplitude modulation of wind turbine noise. *Noise Control Engineering Journal* 59, 38–46
- Leishman, J.G., 2002. Challenges in modelling the unsteady aerodynamics of wind turbines. *Wind Energy* 5, 85–132
- Longhouse, R.E., 1977. Vortex shedding noise of low tip speed, axial flow fans. *Journal of Sound and Vibration* 53, 25–46
- Malovrh, B., Gandhi, F., 2005. Sensitivity of helicopter blade-vortex-interaction noise and vibration to interaction parameters. *Journal of Aircraft* 42, 685–697
- Maffei, L., Iachini, T., Masullo, M., Aletta, F., Sorrentino, F., Senese, V.P., Ruotolo, F., 2013. The effects of vision-related aspects on noise perception of wind turbines in quiet areas. *International Journal of Environmental Research and Public Health* 10, 1681-1697
- McCroskey, W.J., Carr, L.W., McAlister, K.W., 1976. Dynamic stall experiments on oscillating airfoils. *AIAA Journal* 14, 57–63
- McCroskey, W.J., 1981. The phenomenon of dynamic stall. NASA Ames Research Center, Moffett Field, United States
- Meyers, J., Meneveau, C., 2012. Optimal turbine spacing in fully developed wind farm boundary layers. *Wind Energy* 15, 305–317
- Møller, H., Pedersen, C.S. 2011. Low-frequency noise from large wind turbines, 2011. *The Journal of the Acoustical Society of America* 129, 3727-3744.
- Mo, J-O., Choudhry, A., Arjomandi, M., Lee, Y-H., 2013. Large eddy simulation of the wind turbine wake characteristics in the numerical wind tunnel model. *Journal of Wind Engineering and Industrial Aerodynamics* 112, 11–24

- Moreau, S., Roger, M., Christophe, J., 2009. Flow features and self-noise of airfoils near stall or in stall. In *Proceedings of the 15th AIAA/CEAS Aeroacoustics Conference*
- Moriarty, P., Guidati, G., Migliore, P., 2005. Prediction of turbulent inflow and trailing-edge noise for wind turbines. *Proceedings of the 11th AIAA/CEAS Aeroacoustics Conference*
- Nobbs, B., Doolan, C.J., Moreau, D.J., 2012. Characterisation of noise in homes affected by wind turbine noise. *Proceedings of Acoustics 2012 – Fremantle*.
- Norris, S.E., Cater, J.E., Stol, K.A., Unsworth, C.P., 2010. Wind turbine wake modelling using large eddy simulation. In *Proceedings of the 17th Australasian Fluid Mechanics Conference*.
- NSW Department of Planning & Infrastructure (NSW DPI), 2011. NSW planning guidelines: Wind farms. NSW DPI, Sydney, Australia
- Nygaard, Ø.V., 2011. *Wake behind a horizontal-axis wind turbine*. Masters thesis, Norwegian University of Science and Technology, Trondheim, Norway
- Oerlemans, S., Schepers, J.G., 2009. Prediction of wind turbine noise and validation against experiment. *International Journal of Aeroacoustics* 8, 555–584
- Pedersen, E., and Persson Waye, K., 2004. Perception and annoyance due to wind turbine noise—a dose–response relationship. *The Journal of the Acoustical Society of America*, 3460-3470
- Pedersen, E., Van den Berg, F., Bakker, R., Bouma, J., 2009. Response to noise from modern wind farms in the Netherlands. *The Journal of the Acoustical Society of America* 126, 634-643
- Persson Waye, K., Öhrström, E., 2002, Psycho-acoustic characters of relevance for annoyance of wind turbine noise. *Journal of Sound and Vibration* 250, 65–73
- Plovsing, B., Søndergaard, B. 2011. Wind turbine noise propagation: Comparison of measurement and predictions by a method based on geometrical ray theory. *Noise Control Engineering Journal* 59, no. 1, 10-22
- Porté-Agel, F., Wu, Y-T., Lu, H., Conzemius, R.J., 2011. Large-eddy simulation of atmospheric boundary layer flow through wind turbines and wind farms. *Journal of Wind Engineering and Industrial Aerodynamics* 99, 154–168
- Réthoré, P.-E., Troldborg, N., Zahle, F., Sørensen, N.N., 2011. Comparison of the near wake of different kinds of wind turbine CFD models. *Wake Conference Book of Abstracts*, 33-38
- Roger, M., Moreau, S., 2005. Back-scattering correction and further extensions of Amiet's trailing-edge noise model. Part 1: Theory. *Journal of Sound and Vibration* 286, 477–506
- Roger, M., Moreau, S., Guédel, A., 2006. Vortex-shedding noise and potential-interaction noise modeling by a reversed Sears' problem. *Proceedings of the 12th AIAA/CEAS Aeroacoustics Conference and Exhibit*, 8–10
- Ruotolo, F., Senese, V.P., Ruggiero, G., Maffei, L., Masullo, M., Iachini, T., 2012. Individual reactions to a multisensory immersive virtual environment: the impact of a wind farm on individuals. *Cognitive processing* 13. 319-323.
- Sawin, J., 2013, Renewables 2013: Global status report. REN21, Paris, France
- Schlinker, R.H., Amiet, R.K., 1983. *Rotor-vortex interaction noise*. National Aeronautics and Space Administration, Scientific and Technical Information, Hampton, United States.
- Sezer-Uzol, N., Long, L.N., 2006. 3-D time-accurate CFD simulations of wind turbine rotor flow fields. *AIAA Paper No. 2006-0394*
- Shen, W.Z., Zhu, W.J., Sørensen, J.N., 2012. Actuator line/Navier-Stokes computations for the MEXICO rotor: comparison with detailed measurements. *Wind Energy* 2012, no. 15, 811-825
- Shipley, D.E., Miller, M.S., Robinson, M.C., 1995. Dynamic stall occurrence on a horizontal axis wind turbine blade. National Renewable Energy Lab, Golden, United States

- Simms, D.A., Schreck, S., Hand, M., Fingersh, L.J., 2001. *NREL unsteady aerodynamics experiment in the NASA-Ames wind tunnel: A comparison of predictions to measurements*. National Renewable Energy Laboratory Colorado, USA
- Smith, M., Bullmore, A.J., Cand M.M., Davis, R., 2012. Mechanisms of amplitude modulation in wind turbine noise. In *Proceedings of the Acoustics 2012 Nantes Conference*, 823-828
- Sørensen, J.N., Mikkelsen, R., Troldborg, N., 2007. Simulation and modelling of turbulence in wind farms. In *Proceedings of European Wind Energy Conference & Exhibition 2007*.
- Thomsen, K., Sørensen, P., 1999. Fatigue loads for wind turbines operating in wakes. *Journal of Wind Engineering and Industrial Aerodynamics* 80, 121–136
- Thorne, B., 2011. The problems with “noise numbers” for wind farm noise assessment. *Bulletin of Science, Technology & Society* 31, 262–290
- Troldborg, N., Sørensen, J.N., Mikkelsen, R., 2010. Numerical simulations of wake characteristics of a wind turbine in uniform inflow. *Wind Energy* 13, 86–99
- Van den Berg, G.P., 2004. Effects of the wind profile at night on wind turbine sound. *Journal of Sound and Vibration* 277, 955–970
- Vermeer, L.J., Sørensen, J.N., Crespo, A., 2003. Wind turbine wake aerodynamics. *Progress in Aerospace Sciences* 39, 467–510
- Widnall, S., 1971. Helicopter noise due to blade-vortex interaction. *The Journal of the Acoustical Society of America* 50, 354-365
- Willshire, W.L., 1985. Long-range downwind propagation of low-frequency noise. *NASA Technical Report*
- Zahle, F., Sørensen, N.N., 2007. On the influence of far-wake resolution on wind turbine flow simulations. *Journal of Physics: Conference Series* 75
- Zhang, S., Li, H., Liu, X., Zhang, H., Shu, C-W., 2013. Classification and sound generation of two-dimensional interaction of two Taylor vortices. *Physics of Fluids* 25
- Zhu, W.J., Heilskov, N.H., Shen, W.Z., Sørensen, J.N., 2005. Modeling of aerodynamically generated noise from wind turbines. *Journal of Solar Energy Engineering* 127, no. 4, 517-528